

Solenoid Replacement for Mitsubishi Starters

This instruction manual details the removal and replacement of the solenoid for the following starters:
FL0579 and MK0077



Be sure to follow proper safety techniques as outlined by your shop or employer. This includes wearing safety glasses and gloves at all times, and disconnecting the vehicle's batteries during any repair of the starting system.

The components listed below may continue to have power supplied to them even when the ignition switch is off. Use extreme caution at all times.

Disconnect the vehicle's batteries before any service to the starting system.

Solenoid Removal Instructions

- 1) Remove starter from vehicle: Remove vehicle's battery, ground and switch cables from the starter. Remove three starter mounting bolts. See starter installation guide at Diamond-Gard.com for complete removal instructions.
- 2) Remove nuts from solenoid's M terminal, and starter's ground terminal. These terminal locations are shown in Figure 1. Disconnect cables connecting solenoid to the motor
- 3) Remove three solenoid screws connecting solenoid to drive housing. This step is most easily performed using an impact driver as shown in Figure 2
- 4) Remove solenoid from starter by pulling back and lifting upward. The solenoid is most easily removed with the pinion extended

Solenoid Replacement Instructions

- 1) Align the rubber packing's mounting holes with mounting holes on solenoid
- 2) Re-connect solenoid's plunger with starter's shift lever as shown in Figure 3. This is most easily done with the pinion extended. The solenoid M terminal's threaded post is shorter than the B terminal's threaded post. The M terminal should be closest to the motor
- 3) Push solenoid towards pinion end of starter while tightening 3 solenoid securing screws provided with replacement kit. Do not re-use old screws, as new screws are coated with fresh thread locking compound. Ensure rubber packing is seated properly between solenoid and front bracket
- 4) Re-connect wires as shown in Figure 1
- 5) Torque all connections to values shown in Table 1

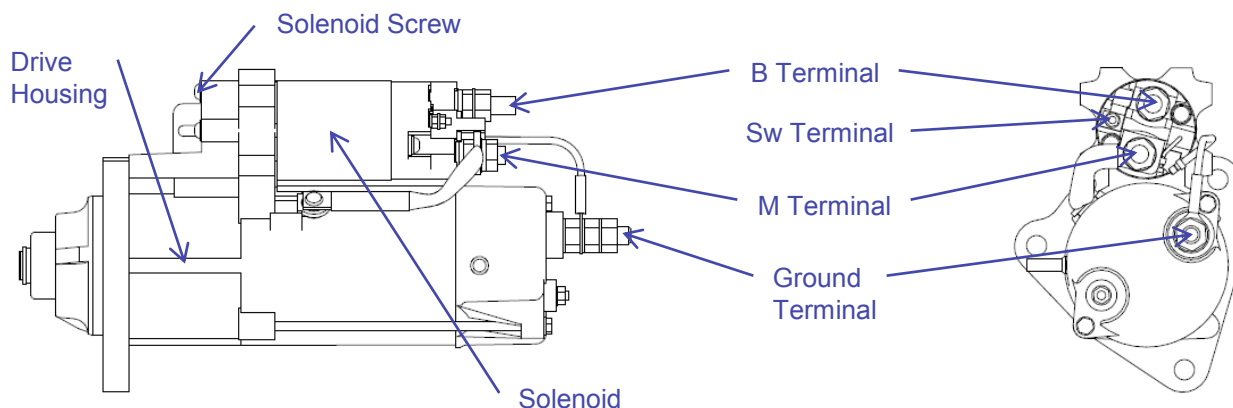

Figure 1: Starter Component Locations

	Solenoid Screw	<u>B</u>	<u>M</u>	<u>Ground</u>	<u>SW</u>	Mounting Bolts
lb.ft	3.6-6.5	15-22	15-22	15-22	1.5-1.8	74-147
lb.in	43-78	180-264	180-264	180-264	18-22	
N.m	4.9-8.8	20-30	20-30	20-30	2.0-2.5	100-200
Size		M12	M12	M12	M5	

Table 1

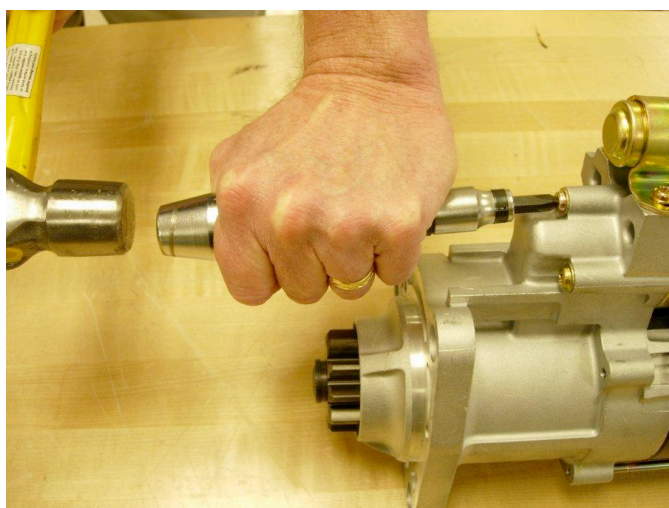

Figure 2: Impact Driver

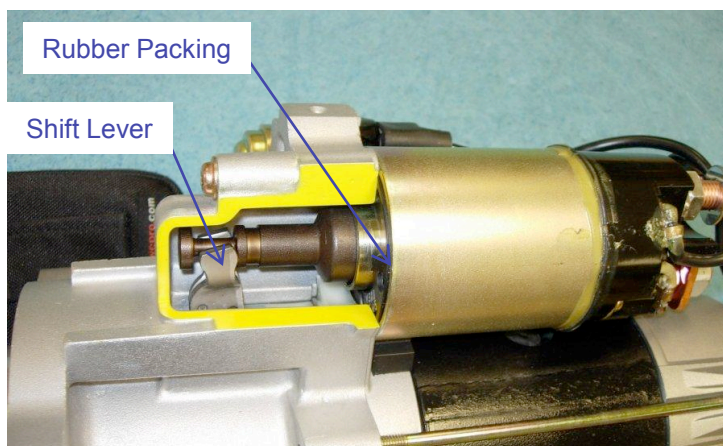

Figure 3: Shift Lever and Rubber Packing

Solenoid Replacement for Mitsubishi Starters

This instruction manual details the removal and replacement of the solenoid for the following starters: PC 1779, PC1879, VV0279, VV0776, VV2079, MK2078, FL1179, and FL0777



Be sure to follow proper safety techniques as outlined by your shop or employer. This includes wearing safety glasses and gloves at all times, and disconnecting the vehicle's batteries during any repair of the starting system.

The components listed below may continue to have power supplied to them even when the ignition switch is off. Use extreme caution at all times.

Disconnect the vehicle's batteries before any service to the starting system.

Solenoid Removal Instructions

- 1) Remove starter from vehicle: Remove vehicle's battery, ground and switch cables from the starter. Remove three starter mounting bolts. See starter installation guide at Diamond-Gard.com for complete removal instructions.
- 2) Remove nuts from solenoid's M, B and Sw Terminals, and starter's ground terminal. These terminal locations are shown in Figure 1. Disconnect cables connecting solenoid to the motor and Integrated Magnetic Switch (IMS)
- 3) Remove three solenoid screws connecting solenoid to drive housing. This step is most easily performed using an impact driver as shown in Figure 2
- 4) Remove solenoid from starter by pulling back and lifting upward. The solenoid is most easily removed with the pinion extended

Solenoid Replacement Instructions

- 1) Align the rubber packing's mounting holes with mounting holes on solenoid
- 2) Re-connect solenoid's plunger with starter's shift lever as shown in Figure 3. This is most easily done with the pinion extended. The solenoid M terminal's threaded post is shorter than the B terminal's threaded post. The M terminal should be closest to the motor
- 3) Push solenoid towards pinion end of starter while tightening 3 solenoid securing screws provided with replacement kit. Do not re-use old screws, as new screws are coated with fresh thread locking compound. Ensure rubber packing is seated properly between solenoid and front bracket
- 4) Re-connect wires as shown in Figure 1
- 5) Torque all connections to values shown in Table 1

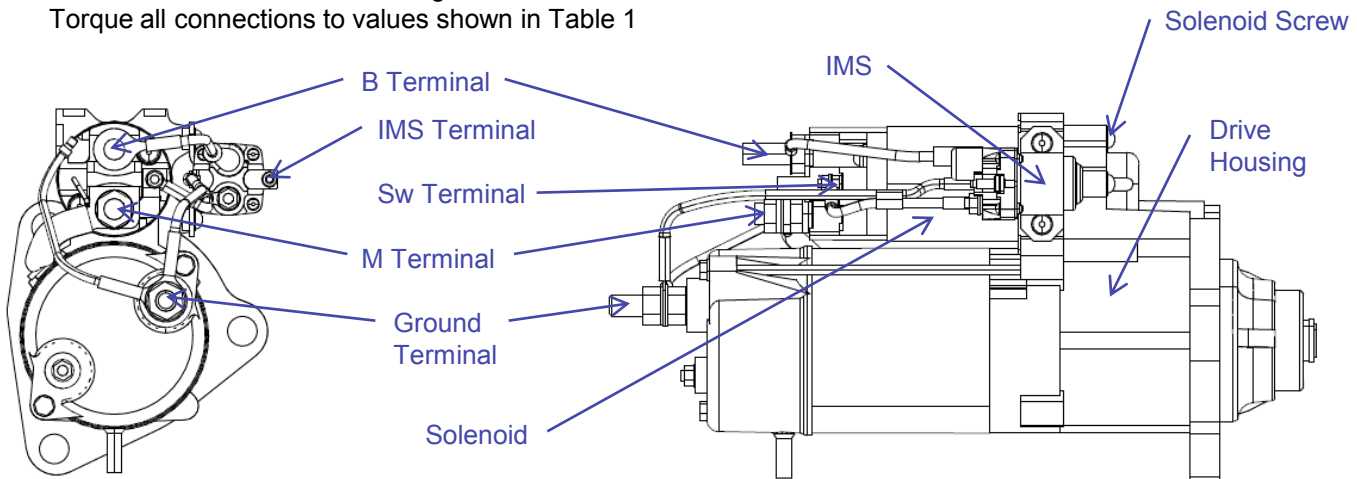

Figure 1: Starter Component Locations

	Solenoid Screw	<u>B</u>	<u>M</u>	<u>Ground</u>	<u>IMS</u>	<u>SW</u>	Mounting Bolts
lb.ft	3.6-6.5	15-22	15-22	15-22	1.5-1.8	1.5-1.8	74-147
lb.in	43-78	180-264	180-264	180-264	18-22	18-22	
N.m	4.9-8.8	20-30	20-30	20-30	2.0-2.5	2.0-2.5	100-200
Size		M12	M12	M12	M5	M5	

Table 1

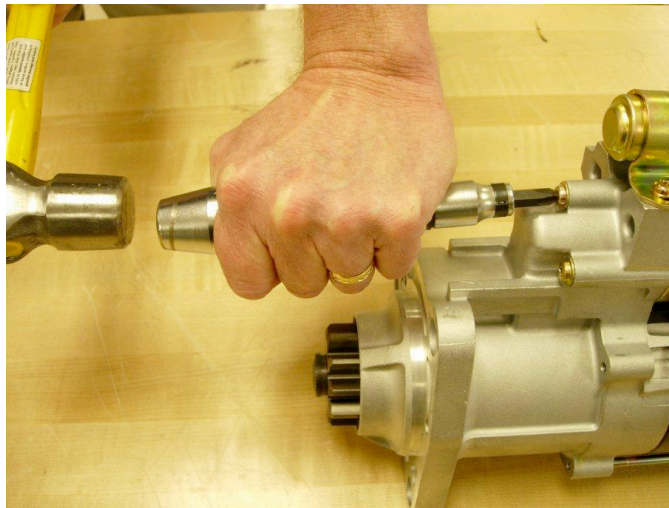

Figure 2: Impact Driver

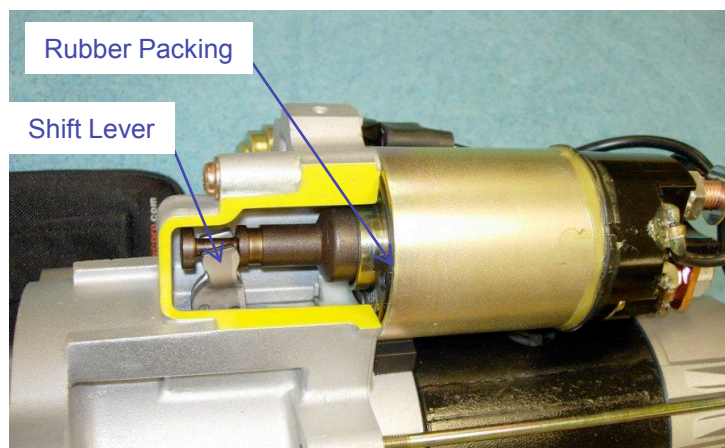

Figure 3: Shift Lever and Rubber Packing

Solenoid Replacement for Mitsubishi Starters

This instruction manual details the removal and replacement of the solenoid for the following starters: PC0979, PC1379, VV0977, VV0879, VV1979, MK1978, PV2479, MC2378, AND FL0975



Be sure to follow proper safety techniques as outlined by your shop or employer. This includes wearing safety glasses and gloves at all times, and disconnecting the vehicle's batteries during any repair of the starting system.

The components listed below may continue to have power supplied to them even when the ignition switch is off. Use extreme caution at all times.

Disconnect the vehicle's batteries before any service to the starting system.

Solenoid Removal Instructions

- 1) Remove starter from vehicle: Remove vehicle's battery, ground and switch cables from the starter. Remove three starter mounting bolts. See starter installation guide at Diamond-Gard.com for complete removal instructions.
- 2) Remove nuts from solenoid's M, B and Sw Terminals, and starter's ground terminal. These terminal locations are shown in Figure 1. Disconnect cables connecting solenoid to the motor and Integrated Magnetic Switch (IMS)
- 3) Remove three solenoid screws connecting solenoid to drive housing. This step is most easily performed using an impact driver as shown in Figure 2
- 4) Remove solenoid from starter by pulling back and lifting upward. The solenoid is most easily removed with the pinion extended

Solenoid Replacement Instructions

- 1) Align the rubber packing's mounting holes with mounting holes on solenoid
- 2) Re-connect solenoid's plunger with starter's shift lever as shown in Figure 3. This is most easily done with the pinion extended. The solenoid M terminal's threaded post is shorter than the B terminal's threaded post. The M terminal should be closest to the motor
- 3) Push solenoid towards pinion end of starter while tightening 3 solenoid securing screws provided with replacement kit. Do not re-use old screws, as new screws are coated with fresh thread locking compound. Ensure rubber packing is seated properly between solenoid and front bracket
- 4) Re-connect wires as shown in Figure 1
- 5) Torque all connections to values shown in Table 1

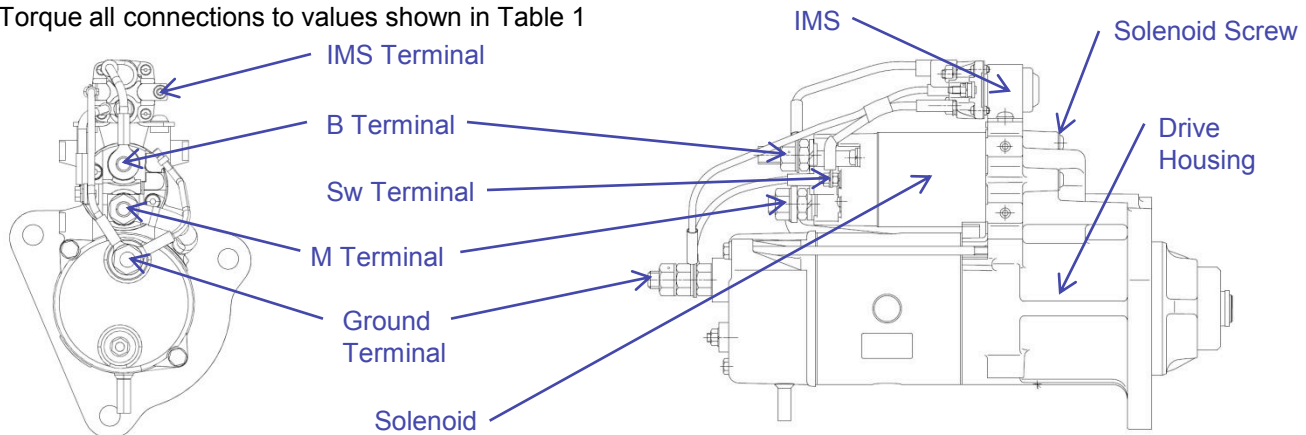

Figure 1: Starter Component Locations

	Solenoid Screw	<u>B</u>	<u>M</u>	<u>Ground</u>	<u>IMS</u>	<u>SW</u>	Mounting Bolts
lb.ft	3.6-6.5	15-22	15-22	15-22	1.5-1.8	1.5-1.8	74-147
lb.in	43-78	180-264	180-264	180-264	18-22	18-22	
N.m	4.9-8.8	20-30	20-30	20-30	2.0-2.5	2.0-2.5	100-200
Size		M12	M12	M12	M5	M5	

Table 1

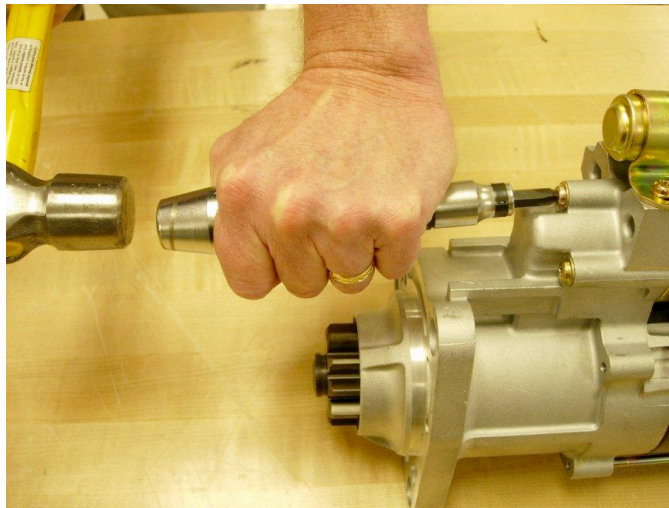

Figure 2: Impact Driver

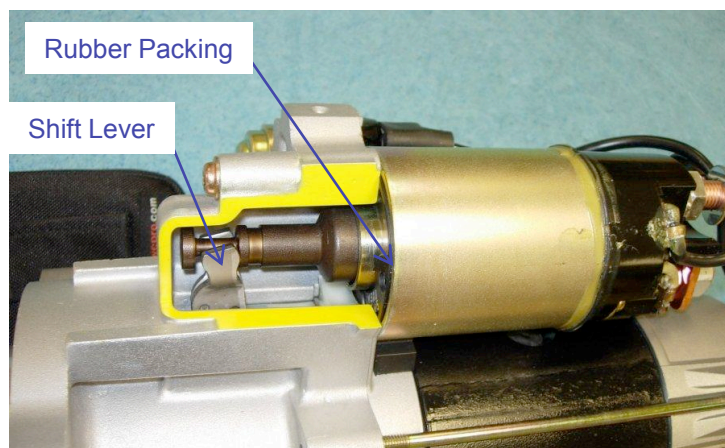

Figure 3: Shift Lever and Rubber Packing